

MODEL #22161
 DOUBLE TIER
 DESIGNER LOCKER - 1 WIDE

(2) LOCKER COMPARTMENTS
 EACH COMPARTMENT:
 13 $\frac{3}{4}$ " W x 34 $\frac{3}{4}$ " H x 19 $\frac{3}{4}$ " D

(NOTE: DESIGNER LOCKER
 SHOWN WITHOUT SIDE PANEL
 OR SLOPING HOOD. PLEASE
 ORDER SEPARATELY.)

SIDE VIEW

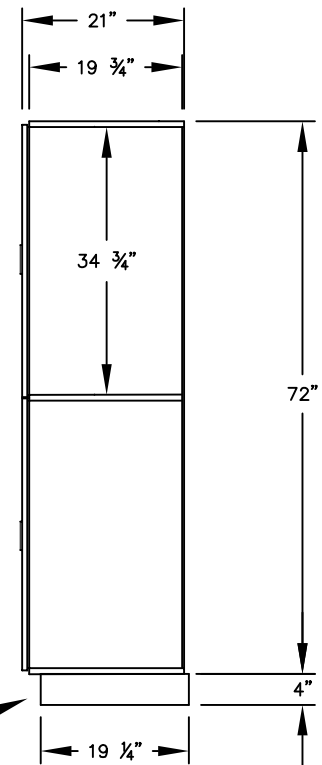

(BASES ARE MADE OF INDUSTRIAL GRADE
 PARTICLEBOARD AND ARE COVERED IN A
 DURABLE BLACK LAMINATE. PLEASE SET
 BASE TO ALLOW $\frac{5}{8}$ " BETWEEN THE BACK OF
 THE LOCKER AND THE WALL FOR AIR
 VENTILATION.)

MODEL #22161

15" WIDE DOUBLE TIER
 DESIGNER WOOD LOCKER
 SIX FEET HIGH (ADD 4" FOR BASE)

AVAILABLE FINISHES: GRAY, BLUE, BLACK,
 MAPLE, CHERRY OR MAHOGANY

DRAWN: 07/18

***Established in 1936, Salsbury Industries is the industry
 leader in manufacturing and distributing quality lockers.***

1010 E. 62ND STREET
 LOS ANGELES, CA 90001
 PHONE: (800) 562-5377
 FAX: (800) 562-5399
 email: engineering@lockers.com